

INSTALLATION GUIDELINES

For Next Dimension Sliding Patio Doors

Installer

- Read instructions completely before attempting installation. Failure to follow these guidelines will forfeit all the Windsor warranty coverage, (written or implied). Windsor Windows & Doors will not be held responsible for any claims or damages resulting from installation.
- Sliding Doors Adjustment: The door panels of Sliding Operating Doors must be adjusted to ensure proper operation and performance. The door panels must be adjusted so the gap between the panel and the frame is consistent. The width of the gaps on the left and right should be similar. The width of the gaps on the top and bottom should be similar. All the gaps should be uniformly straight from one end to another. If you have questions, please see Windsor's Care and Use Guide
CAUTION: Misaligned door panels will result in a misaligned seal which will adversely affect the performance of the door. As a result, the failure to maintain proper door panel adjustment will void Windsor's warranty.
- Always provide a copy of these instructions to the homeowner.
- These instructions are consistent with ASTM 2112 "Standard Practice for Installation of Exterior Windows, Doors and Skylights" into common wall constructions. For installation into air barrier sheathing systems such as ZIP System, refer to our supplemental installation instructions at www.windsorwindows.com. Contact your architect or construction professional for installation into other building designs or construction methods.
- Regional codes and environmental conditions may require installation that is different from these guidelines. It is your responsibility to ensure that local codes and ordinances are followed.

Warning

- ⚠ **Work Safe!** Always wear proper eye and hearing protection when installing or adjusting Windsor products.
- ⚠ **Use Power Tools Properly!** To avoid personal injury, always follow manufacturers' instructions for safe operation of power tools.

- ⚠ **Ladder Safety!** Working at elevated levels can be hazardous. Always use ladders and scaffolding properly. Consult manufacturers' guidelines for safe use of these types of equipment.

Important

- Windsor reserves the right to change the information contained in these guidelines without notice.
- Maintain a minimum of 1/4" between the door frame and any trim, siding or masonry.
- Use of Windsor products in barrier EIFS systems (synthetic stucco) is not recommended. To do so will void all warranties (written or implied) and Windsor Windows & Doors will not be held responsible for any claims or damages resulting from water infiltration.
- Steel fasteners will corrode when used with ACQ pressure treated lumber. Use corrosion-resistant fasteners (such as stainless steel) when installing doors in or around these types of materials.
- Door nailing flanges and drip caps (integral or applied) do not take the place of door flashing. All windows and doors must be properly flashed and sealed around the perimeter.

Handling and Storage

CAUTION: Prefinished Interiors: Windsor products with prefinished interiors must be protected from dents, scratches, scrapes or other blemishes. Windsor does not warrant against dents, scratches, scrapes or other damage to prefinished interiors after the Windsor products leave Windsor's possession.

After the Windsor products leave Windsor's possession, extreme care must be taken by those moving the doors, or those working on or around the doors, to protect prefinished interiors from dents, scratches, scrapes or other blemishes.









Follow these procedures for proper storage and handling of windows and doors:

- Remove stretch wrap immediately so the individual units can be exposed to circulated air.
- Do not store units outside or in direct sunlight. Allow sufficient spacing between products for ventilation.
- Never store units in a closed truck or other similar enclosure where the units can get too hot.
- Never stack or lean units against each other in the sun.
- Always store units vertically. Do not store units flat or stack horizontally.
- Units must be stored in a clean, dry, well-ventilated and enclosed area.
- Units with unsupported nailing fins should have their corners blocked and protected to prevent damage to the nailing fin.
- Always carry door units upright. Do not carry flat! Doing so could result in damage to the unit.

Failure to follow these procedures will void our product warranty.

IMPORTANT! IF VINYL WINDOWS AND DOORS ARE NOT INSTALLED IMMEDIATELY UPON DELIVERY, THEY MUST BE PROPERLY STORED AND PROTECTED UNTIL INSTALLED. If the vinyl product is not stored properly, distortion of the frames can occur affecting operation and performance. Vinyl windows and doors should be installed within 30-60 days of receiving.

Tools Needed

- Safety Glasses 
- Utility Knife 
- Hammer (or nail gun) 
- Caulk Gun 
- Level 
- Ladder / Scaffolding 
- Square 
- Tape Measure 
- Stapler 

Materials Needed

- Backer Rod
 - 1/4"-1/2" diameter closed cell foam
- Insulation
 - Minimally expanding low pressure polyurethane window and door foam
- Shims
 - Made of cedar or synthetic material
- Roofing Nails
 - 11 ga. x 2-1/2" galvanized
- Silicone Sealant
 - 100% Silicone
 - Neutral cure (modified oxime) only
- Flashing
 - Self-adhesive flexible flashing that complies with AAMA-711

LEAD PAINT AND EXISTING DOOR DISPOSAL:

- A) Before any remodel or renovation, make sure to identify any potential lead paint issues and take necessary steps to reduce the risk of lead contamination.
- B) The U.S. Environmental Protection Agency (EPA) has issued a “Lead Renovation, Repair and Painting Rule (RRP)” for remodelers of older homes and buildings. This rule requires training and certification in lead-safe work practices for firms performing renovation, repair or painting on homes and child-occupied facilities built prior to 1978.
- C) For more information regarding procedures for dealing with lead paint, please visit EPA’s website at www.epa.gov/lead.
- D) When removing existing doors, make sure to wear appropriate personal protective equipment. Extra precautions should be taken to protect others and property within the vicinity and below the removal door and surrounding components.
- E) Consult with local waste authorities on the proper recycling or disposal of old door components.

ATTENTION! ARBITRATION AGREEMENT; JURY TRIAL WAIVER; CLASS ACTION WAIVER. By purchasing, installing, or using this product, you agree to arbitrate any dispute you may have with Windsor relating to your Windsor products, and to waive your rights to a jury trial and to participate in class-action or class-arbitration proceedings, relating to any such disputes. For more details, and to learn how **YOU CAN OPT OUT OF THIS ARBITRATION AGREEMENT AND THESE WAIVERS**, please go to www.windsorwindows.com/support/DisputeResolution.

Step 1: Inspect Unit

Before Installation:

- A) Remove all shipping packaging material (blocks, pads, protectors, stretch wrap).
- B) Inspect unit for any damage or defects.
- C) Verify that the door is the correct size and configuration.
- D) Make sure the unit operates properly.
- E) Contact the nearest Windsor distributor if there are any problems.

Step 2: Apply Jamb Extension Clips or Drywall Return

- A) Place a 1/8" diameter bead of 100% neutral cure sealant around the perimeter interior accessory groove. (Fig. 1)
- B) Install the 3" jamb extension clips around the perimeter of the frame, two on each corner, and then spaced on approximately 18" intervals along the frame. (Fig. 2) **Note: For drywall return, install lineal pieces.**
- C) Position the jamb extension as shown against the clips and staple or screw through the clip into the backside of the jamb extension. (Fig. 2)
- D) Wrap jamb extension around the door frame. (Fig. 3)

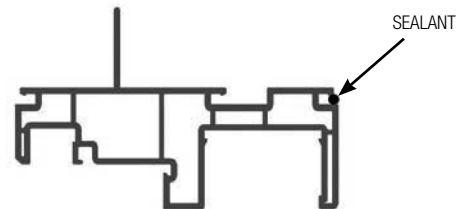

FIG. 1

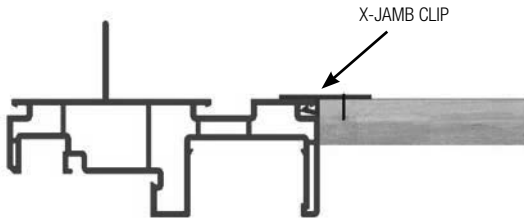
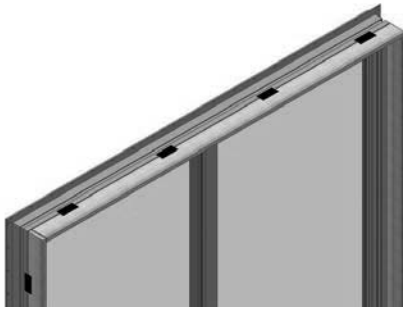

FIG. 2

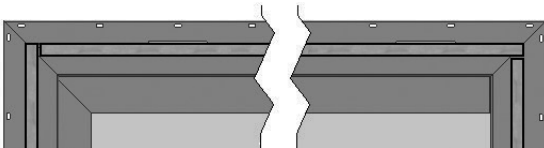

FIG. 3

Step 3: Prepare Rough Opening

- A) Measure and verify the size of the rough opening. The rough opening should be 1/2" larger than the frame in height and 3/4" larger than in width.
- B) Verify the rough opening is plumb, level and square. (Fig. 4)
- C) Take diagonal measurements to check for square. (Fig. 4)
- D) Make sure the bottom sill area of the rough opening is flat and level. Correct rough opening if sloped toward interior, out of level, or humped. (Fig. 4)
- E) Make an "I-Cut" in the weather-resistant barrier (WRB). Begin with a horizontal cut along the bottom and the top of the rough opening. Then make a vertical cut in the center from top to bottom. (Fig. 5)
- F) From the exterior, cut the top of the WRB to form a flap. (Fig. 5 & 6)
- G) Fold side flaps into rough opening and secure to inside wall. Cut off excess flap if desired. (Fig. 6)

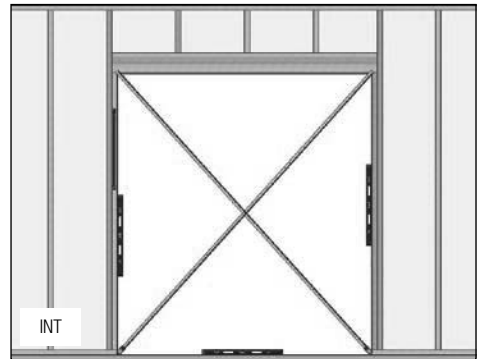

FIG. 4

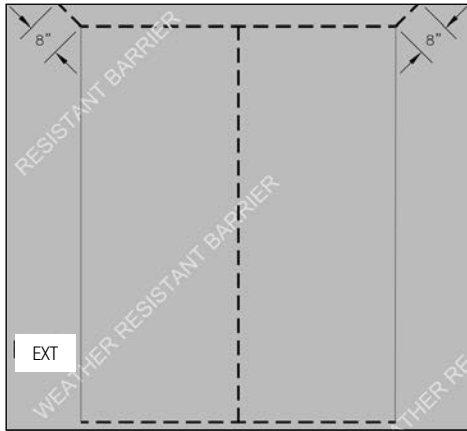

FIG. 5

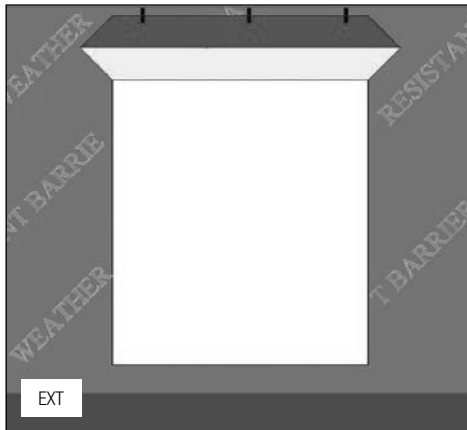

FIG. 6

Step 4: Flashing the Sill

A) IMPORTANT:

- Use flashing that is 6" minimum in width.
- Flashing must meet AAMA-711 performance requirements.
- Adhesive or mechanically-fastened flashing may be used.

B) Measure the width of the rough opening. Cut a length of flashing that is 12" wider than the rough opening. This will allow you to run the flashing 6" up each side. (Fig. 7)

C) Cut 1-1/2" slits at each end of the flashing as shown below. (Fig. 7)



FIG. 7

D) Apply sill flashing to the rough opening as shown below. (Fig. 8)

E) If you are using non-adhesive flashing:

- Staple flashing into place.
- Seal corner notches using 100% neutral cure silicone sealant.

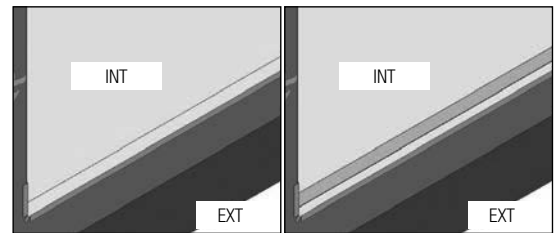

FIG. 8

FIG. 9

F) Flashing tape must cover the entire sill plate. If needed, apply an additional flashing piece over the first one (*start from the exterior and work toward the interior*). Maintain a minimum 1" overlap. (Fig. 9)

- G) Apply two continuous, straight beads of 100% neutral cure silicone sealant to the subfloor to seal the sill to the subfloor. (Fig 10 & 11)

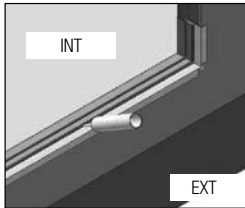

FIG. 10

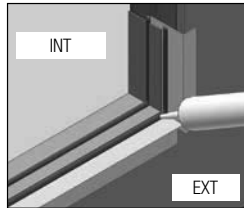

FIG. 11

Step 5: Door Installation

For Impact-rated products and/or any products installed in the Florida or Texas TDI regions, supplemental anchoring methods may be required. Refer to supplemental instructions attached to unit or www.windsorwindows.com for further information.

- A) Remove all packaging material (blocks, pads, protectors, stretch wrap).
- B) Inspect and verify the following:
 - a. The door is the correct size and specification.
 - b. The unit is free from any damage or defects.
- C) Contact the nearest Windsor distributor if there are any problems with Step B above.
- D) Apply sealant:
 - a. Apply a 1/4" diameter bead of 100% neutral cure silicone sealant along the backside of the nailing flange. (Fig. 12)
 - b. Bead must run continuously around both sides and across the head, in line with and completely covering the nailing flange holes. (Fig. 12)
 - c. Use a discontinuous bead at the sill to allow for any drainage. Alternate using a 6" long bead with 1" gaps. (Fig. 13)

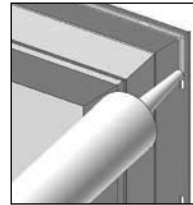

FIG. 12

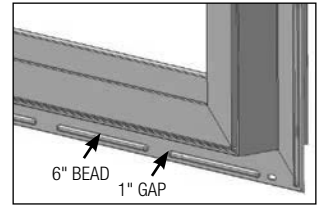

FIG. 13

- E) Set the door into the rough opening. Center the unit in the opening, making sure there are equal gaps on both sides of the door.
- F) Temporarily tack the door into place using 2-1/2" galvanized roofing nails through the pre-punched holes on one top corner of the nailing flange. Do not drive the nails in fully.
- G) Check the unit for square using diagonal measurements. Shim door to ensure the unit is square. Multiple units must have shims under each mull.
- H) Nail all four corners in place through the pre-punched holes in the nailing flange.
- I) Make sure jambs, head and sills are straight. Additional shimming may be required.
- J) Shim jambs midway at lock point. See (Fig. 14) for minimum shim placement.
- K) Finish nailing the door into place through the pre-punched holes in the nailing flange, placing nails within 4" of each corner and no more than 8"-10" in between.

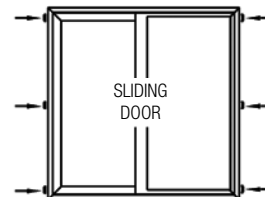

FIG. 14

Installation Fasteners			
Substrate	Fastener	Type of Steel	Minimum Embedment into Framing
Wood	11 ga. Roofing Nail	Galvanized, Stainless Steel, Zinc Plated	2"
Wood	#8 Wood Screw		2"
Steel	#8 Self Tap/Drill Screw		Fully Threaded

Step 6: Complete Flashing

- A) Cut and apply side flashing. Side flashing should run from the bottom of the sill flashing to 8" above the rough opening. (Fig. 15)
- B) If non-adhesive flashing is used, make sure all staple holes are sealed with silicone.
- C) Cut and apply head flashing. The head flashing should run slightly past the edge of the side flashing. (Fig. 16)
- D) Flip down the top flap of the WRB. (Fig. 17)
- E) Tape the cut seams of the WRB. (Fig. 17)

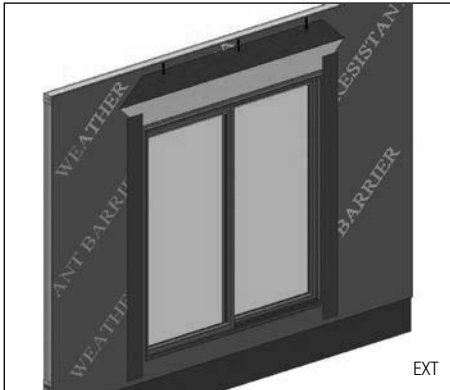

FIG. 15

Step 6: (continued)

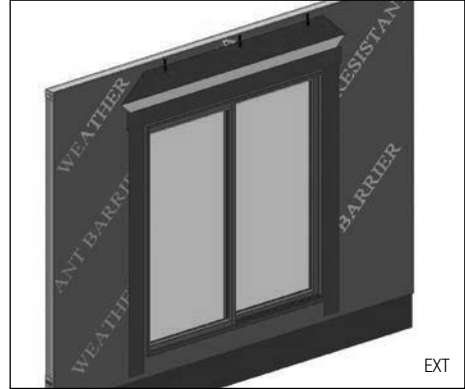

FIG. 16

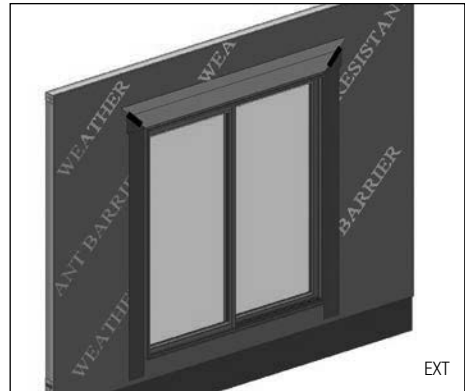

FIG. 17

Step 7: Seal the Exterior

A) Support material is required on exterior sections of sliding patio doors. Install a structural wood support block at sill. (Fig 18)

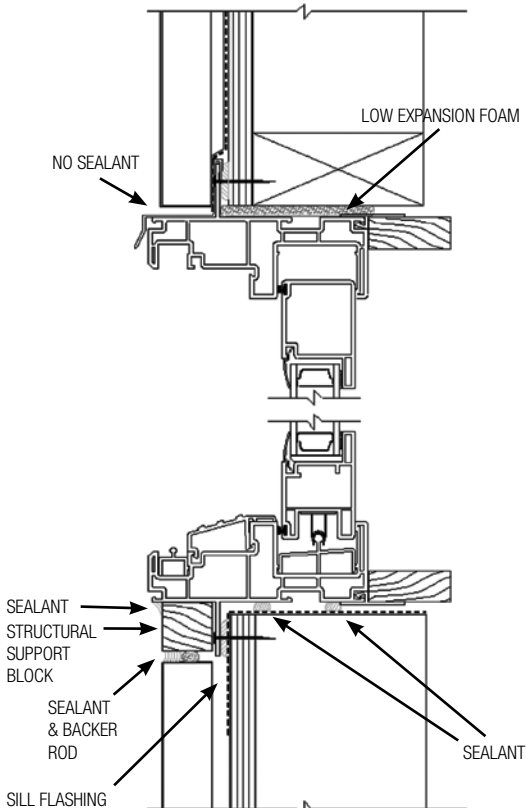

FIG. 18

B) **WARNING:** Maintain a minimum of 1/4" between the door frame and any trim, siding or masonry. Failure to do so will forfeit all warranties (written or implied). Windsor Windows & Doors will not be held responsible for any claims or damages resulting from failure to follow these instructions.

C) After siding or wall exterior is complete, apply backer rod and sealant between the door frame and siding material on both sides and sill. Make sure to use 100% neutral cure silicone sealant. (Fig 19)

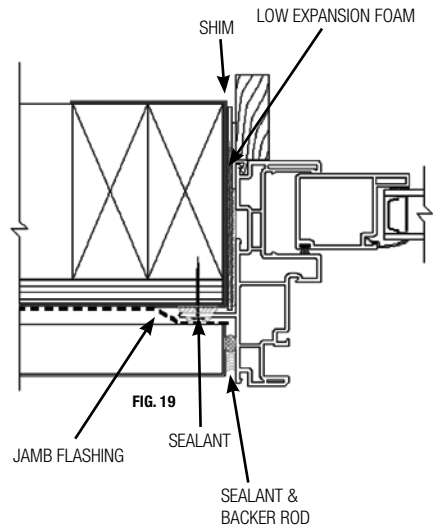

FIG. 19

Step 8: Completing the Installation

- A) Install a seal around the full interior perimeter of the opening. On the side/jamb and top, apply minimally expanding window and door spray foam insulation. Use caution not to overfill the gap, causing the side/jamb to bow. It is not recommended to apply trim to the unit until the foam has cured to allow excess to escape. On the sill, apply a bead of sealant between the sill flashing and the window frame (Fig.18 & Fig.19)
- B) Operate unit to ensure proper operation. The sliding panel will not operate correctly if door is out of square, over-shimmed or over-insulated.
- C) Remove all labels or shipping materials.
- D) Paint or stain all interior wood components.
 - **Painting:** Apply primer to unprimed wood surfaces that will be painted. Two coats of high-quality interior trim enamel (latex or oil-based) should be applied in accordance to the paint manufacturer's specifications.
 - **Staining:** Apply stain according to the manufacturer's recommendations. Two coats of high-quality clear finish coat should be applied over any stain.
- E) **IMPORTANT:** Do not stain or paint any vinyl components.

Step 9: Quad Patio Door Only

- A) Once the frame is completely installed, install both panels into the door frame without the astragal attached.
- B) After the panels are installed, adjust the rollers so that each panel is parallel with the side jamb. Roller adjustment screws are located near the bottom edges of the panel and each panel corner can be adjusted up or down using a Philips screw driver.
- C) Locate the secondary panel, the secondary panel will not have a punch out for the lock. **IMPORTANT!** Install the dummy handle set on the secondary panel, or insert a screw driver into handle holes to prevent the stile reinforcement from shifting when screws are removed in the next step.
- D) Once complete, remove all screws on the face of the secondary stile. Set the screws aside to be used later.
- E) Apply the astragal to the secondary stile. The secondary stile will fit into the shallow pocket on the astragal (FIG. 20). Center the astragal vertically in opening. There should be an approximate ¼" gap between the astragal and the head & sill. The square cut-out on the astragal will go towards the bottom of the panel near the roller adjustment screw (FIG. 21).

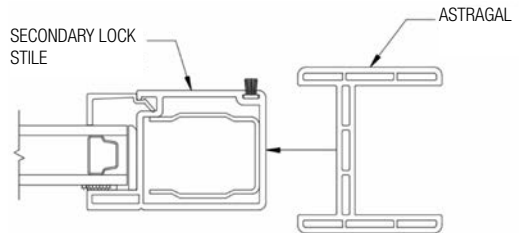

FIG. 20

- F) Attach the astragal to the secondary stile using screws from earlier. Apply the screws in the center of the profile 6" from each end and approximately 12" apart along the full length of the astragal (FIG 21).
- G) Remove the warning label on the astragal and apply the keeper using the $\frac{3}{4}$ " long screws provided with the dummy handle set.
IMPORTANT: DO NOT USE THE 2" SCREWS TO ATTACH THE KEEPER!
- H) Shut & lock door to test keeper alignment.

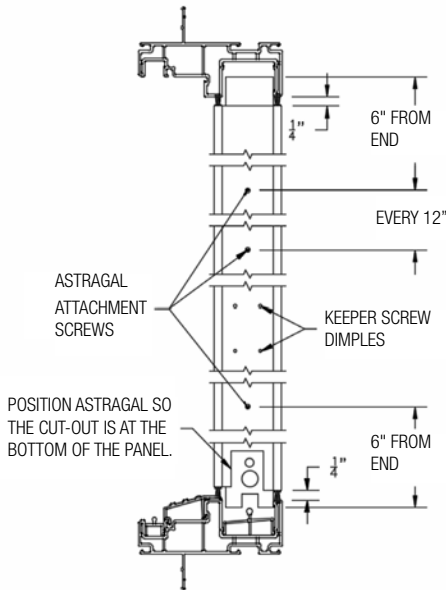

FIG. 21

If you have any questions regarding your Windsor Windows, please contact Windsor Windows & Doors directly at 1-800-218-6186. Or you can visit us online at www.windsorwindows.com, where you will find helpful information as well as our Care and Use Guides, which will assist you in preserving your windows and patio doors. While you are at our site, you can also complete and submit the form on the Contact page, and one of our door specialists will promptly answer your question.

Care and Use

For information about the care and use of your Windsor products, please visit the www.windsorwindows.com/support, and click "Warranty, Care & Installation," where you find a link to our Care and Use Guide. Or contact your local independent Windsor distributor and ask for a copy of the Care and Use Guide, which contains information on finishing, cleaning, what to look for during yearly inspections, general maintenance tips, sash/panel adjustment, sash/panel removal, screen removal and information on condensation. You should inspect your doors annually.

Warranties

You can find a copy of our current Warranty at the website, under the "Support" tab. If you have Windsor products that are older, please contact Windsor at 1-800-218-6186, and we will provide a copy of the applicable warranty.



www.windsorwindows.com